

20

23

**FUNCTIONAL
REFRACTORIES**

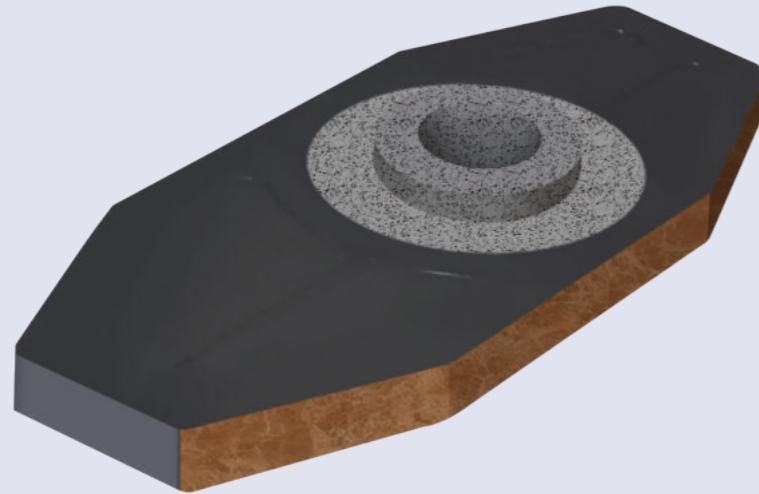

SLIDE GATE PLATE

The products adopt tabular alumina, carbon material and zirconia-containing material as main raw materials, are added high performance anti-oxidant, use phenolic resin as binder, shaped under high-pressure and burned under high temperature. The slide gate plates have the properties of high strength, good erosion resistance, thermal shock resistance and good stability etc. They are mainly used in large, medium and small size ladles.

Specifications

Item	Al ₂ O ₃ -C Slide Gate Plate			Al ₂ O ₃ -ZrO ₂ -C Slide Gate Plate		
	LKLT-75	LKLT-80	LKLT-85	LKLGT-70	LKLGT-75	LKLGT-77
Al ₂ O ₃ , % ≥	75	80	85	70	75	77
C, % ≥	7	5	5	4	3	2
ZrO ₂ , % ≥	----	----	----	3	5	8
显气孔率 (A.P.), % ≤	10	10	10	10	8	8
体积密度 (B.D.), g/cm ³ ≥	2.9	2.9	3.0	3.00	3.05	3.15
常温耐压强度 (C.C.S), MPa ≥	70	100	100	100	115	120

INNER Nozzle

The upper nozzle is made of tabular alumina, white fused alumina, sintered spinel, flake graphite, anti-oxidants and phenolic resin etc, which has the properties of excellent thermal shock stability, good oxidation resistance and high corrosion resistance. It is suitable for all kinds of ladles.

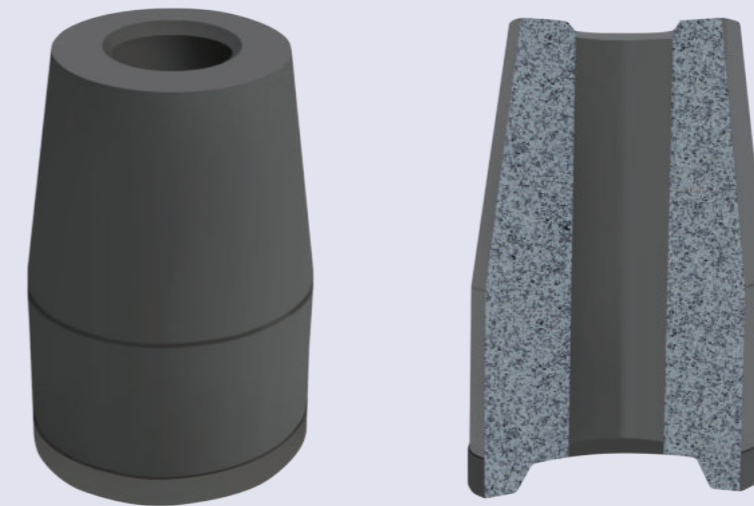

Specifications

Item	LKS-75	LKS-80	LKS-85
Al ₂ O ₃ , % ≥	75	80	85
C, % ≥	4	3	3
显气孔率 (A.P.), % ≤	15	14	12
体积密度 (B.D.), g/cm ³ ≥	2.85	2.90	2.95

COLLECTOR NOZZLE

■ The collector nozzle is made of tabular alumina, white fused alumina, bauxite, flake graphite, anti-oxidants and phenolic resin ect, which has the properties of excellent thermal shock stability, strong corrosion resistance etc.

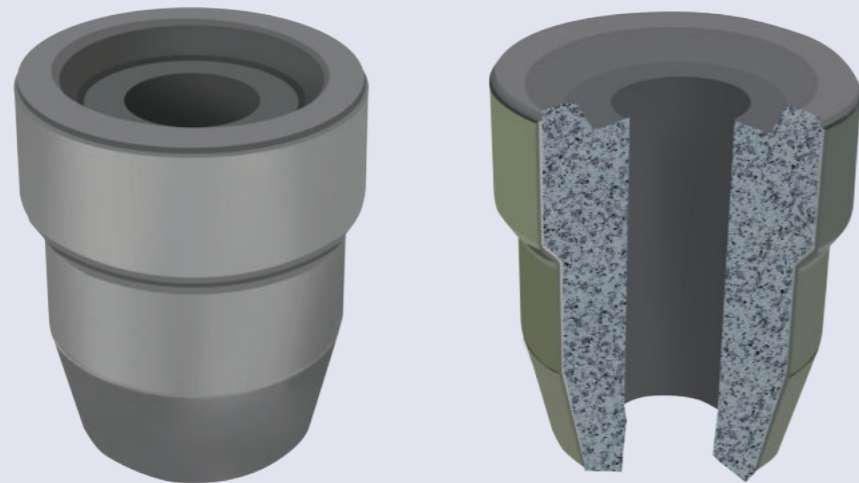

■ Specifications

Item	LKX-65	LKX-75	LKX-85
Al ₂ O ₃ ,% ≥	65	75	83
C,% ≥	2	3	3
显气孔率 (A.P.), % ≤	16	15	14
体积密度 (B.D.),g/cm ³ ≥	2.75	2.80	2.85

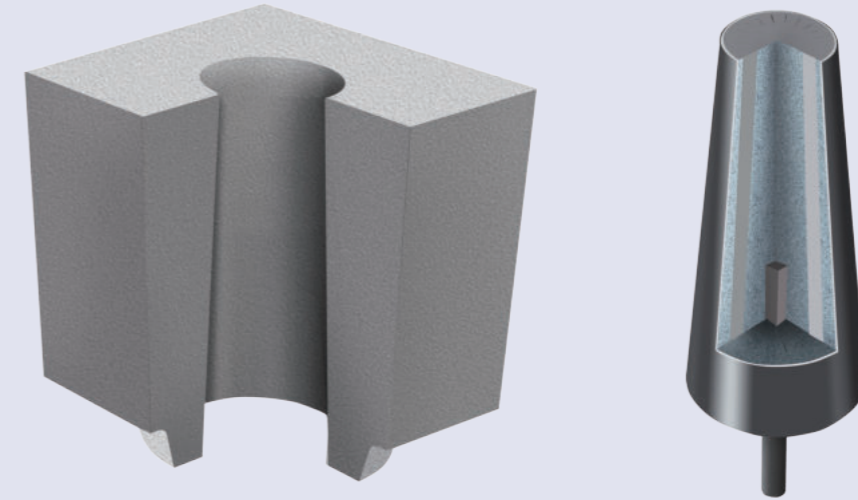

WELL BLOCK & POROUS PLUG

■ The main materials of well blocks & porous plugs are chromiun-corundum and corundum-spinel. Our company adopts tabular alumina, emery, chromium oxide green and magnesium aluminate spinel as main raw materials, uses high alumina cement as binder to produce directional slit porous plug, which has the features of good structural stability, high air permeability, strong corrosion resistant, long service life etc.

■ Specifications

Item	LKWB-90	LKPR-95
Al ₂ O ₃ +MgO,% ≥	92	----
Al ₂ O ₃ +MgO+Cr ₂ O ₃ ,% ≥	----	95
体积密度 (B.D.), g/cm ³ ≥	3.10	3.10
抗折强度 (M.O.R.)MPa(1500°CX3h) ≥	15	15
耐压强度 (C.C.S)MPa(1500°CX3h) ≥	80	90



GUNNING REFARACTORIES FOR EAF



Gunning refractories for EAF is made of high quality dead burned magnesia and other alkaline synthetic materials, adding with certain binding agent. It is characterized by great resistance to slag high adhesive rate, small resilience and easy spray repair.

It is extensively used for the hot repair of the slag line of electric furnace, furnace ramp, furnace wall, tap hole etc.



Ramming mix for EAF bottom is made of fused magnesia or medium-class magnesia and MgO-CaO-Fe₂O₃ sinter. It is characterized by high density, high strength, great resistance to corrosion, great thermal resistance, and long service life.

It is extensively applied to general and ultra high power arc furnace, DC arc furnace and electric refining furnace for ferro-alloy.

REFRACTORY RAMMING MIX

Specifications

		DHL-80	DHL-82	ZDL-65	DTL-84
MgO (%)		≥80	≥80	≥65	≥85
CaO (%)		13-15	11-13	27-29	6-8
Fe ₂ O ₃ (%)		3.5-4.5	3.5-4.5	3.5-4.5	4-5.5
Al ₂ O ₃ (%)		≤0.4	≤0.4	≤0.4	≤0.4
SiO ₂ (%)		≤1.5	≤1.5	≤1.5	≤1.5
L.O.I (%)		≤0.5	≤0.5	≤0.5	≤0.5
Particle size (mm)		0-6	0-6	0-6	0-6
Cold crushing Strength (MPa)	1300°C*3h	≥10	≥10	≥10	≥9
	1600°C*3h	≥30	≥30	≥25	≥30
Linear Change (%)	1300°C*3h	≤0.5	≤0.5	≤0.5	≤0.4
	1600°C*3h	≤2.0	≤2.0	≤2.0	≤2.0
Max.working temperature (°C)		≥1800	≥1800	≥1800	≥1800

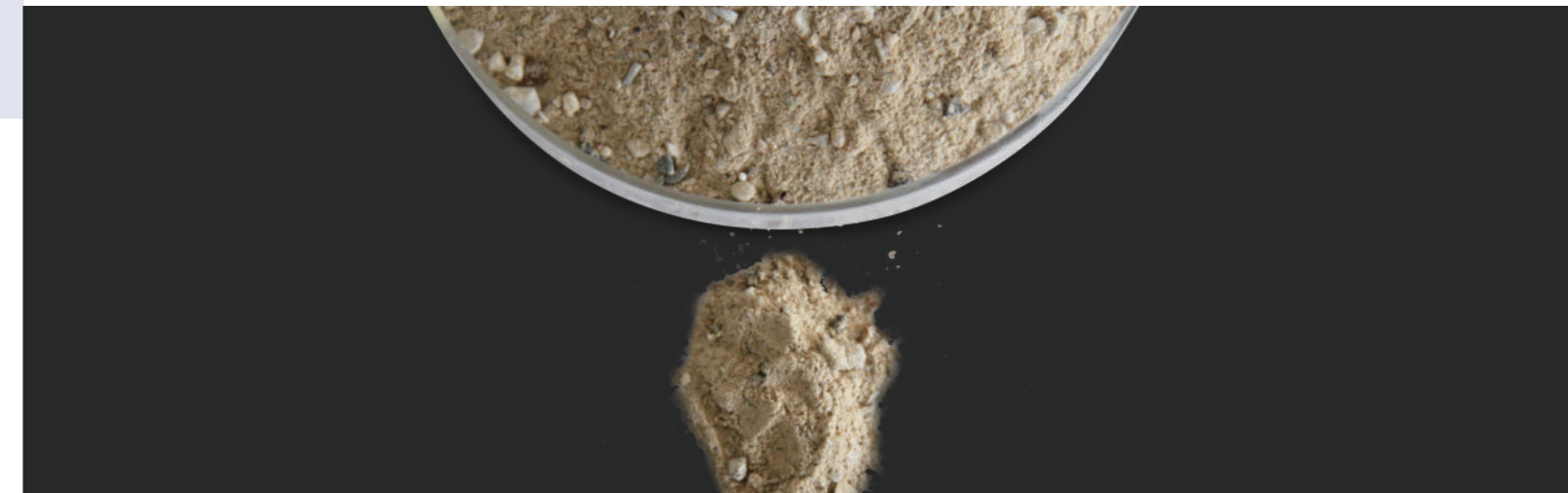

Specifications

	MgO (%)	CaO(%)	SiO ₂ (%)	Grain size (mm)	Working temperature (°C)	Installation method
MDP-88	≥88	≤1.6	≤6.0	0-4	1750	Mechanical Spray Repair
MDP-78	≥78	10-15	≥4.0	0-4	1750	
MDP-65	65-70	15-18	≤6.0	0-4	1750	



TEL./FAX.: 0086-533-2210989
MOBILE: 0086-18678181477
WEB: www.longketer.com
E-Mail: sales@longketer.com

ZIBO LONG KETER NEW MATERIALS CO.,LTD

ADDRESS: 805, BLOCK B, RUNDE PLAZA, BEIJING RD., ZHANGDIAN,
ZIBO, SHANDONG, CHINA 255000